

Servomotor driver MSSMD-50-20

Servomotor Driver MSSMD-50-20

Specifications:

Power Supply

Minimum Voltage : 18 Vdc

Maximum Voltage : 50 Vdc

Maximum output Current : 0 - 20 Amps (adjustable)

Input Signals : STEP and DIRECTION (optocouplers)

Logic Signal Current minimal : 6 mA

Logic Signal Current typical : 12 mA

Logic Signal Current maximal : 20 mA

Maximum input frequentie : 250 Khz

Input from encoder : TTL quadrature signal (A and B)

Lock range before error : +/- 128

Protection : Over-current, short-circuit

Weight : ~100 gram

Size : ~71 x 74 x 26 mm

Outputs

Output Voltage to encoder : + 5 V

Output Current to encoder : 50 mA

Error Output

Optocouplers Inputs:

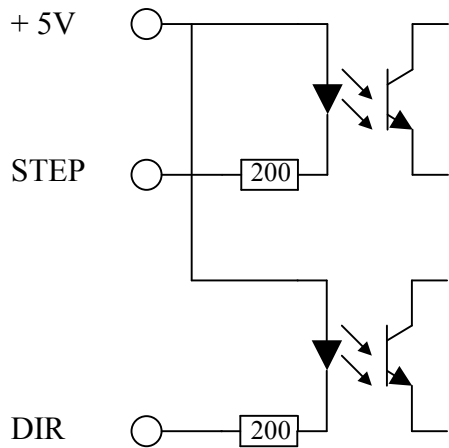

Signals

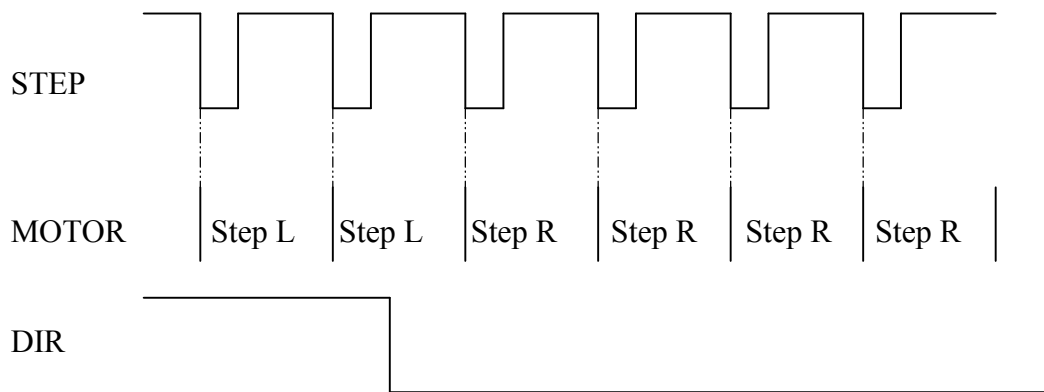

Connections

+ V	: Positive of Power Supply
GND	: Negative of Power Supply (or ground)
+ 5 V	: + 5 V
STEP	: STEP
DIR	: DIRECTION
Motor-	: Motor- terminal
Motor+	: Motor+ terminal
EGND	: Ground of encoder
E+5V	: Internal output to encoder (max 50 mA)
Phase A	: A signal of encoder
Phase B	: B signal of encoder
ERR/RES	: Error output of driver and Reset input to driver

Trimmers

Current
Gain
Damping

Standard Connections (Example)

X-axes

+V : Powersupply
GND : Ground of powersupply

+5V : + 5 V
STEP : LPT – 2
DIR : LPT - 3
Motor+ : X-ax servomotor + terminal
Motor- : X-ax servomotor – terminal
EGND : Ground of encoder X-ax
E+5V : Power to encoder X-ax
PHASE A : Encoder A output
PHASE B : Encoder B output
ERR/RES : Error output and Reset input

Y-axes

+V : Powersupply
GND : Ground of powersupply

+5V : + 5 V
STEP : LPT – 4
DIR : LPT - 5
Motor+ : Y-ax servomotor + terminal
Motor- : Y-ax servomotor – terminal
EGND : Ground of encoder Y-ax
E+5V : Power to encoder Y-ax
PHASE A : Encoder A output
PHASE B : Encoder B output
ERR/RES : Error output and Reset input

Z-axes

+V : Powersupply
GND : Ground of powersupply

+5V : + 5 V
STEP : LPT – 6
DIR : LPT - 7
Motor+ : Z-ax servomotor + terminal
Motor- : Z-ax servomotor – terminal
EGND : Ground of encoder Z-ax
E+5V : Power to encoder Z-ax
PHASE A : Encoder A output
PHASE B : Encoder B output
ERR/RES : Error output and Reset input